



NEXT-GEN CLOSED-CIRCUIT FILTRATION

Designed and fabricated in the UK, the **HydraStream** filtration units remove particulates, suspended solids, and sludge from heating and chilled water systems.

Wherever there is water, there is a risk of fouling, corrosion, scale, and microbiological growth. Left untreated, these issues reduce system efficiency, increase maintenance requirements, and shorten component life.

During fabrication, systems can also become **contaminated** with jointing compounds and construction debris, causing problems from day one.

In normal operation, **water can be corrosive**, producing particulates and sediment. These can accumulate, leading to blockages, uneven heat distribution, and **costly failures** of critical components such as valves, pump seals, and boilers.

Removing these corrosion by-products reduces maintenance, improves heat distribution, and reduces stress on pumps and other equipment.



Cleaner water also allows chemical corrosion inhibitors and biocides to work **more effectively**, as microbiological growth is no longer shielded by particulates. Reducing deposits decreases the surface area available for fouling and helps prevent re-infection of the system.

In addition, sidestream filtration enables removal of trapped air, which can otherwise restrict flow and reduce system performance.

Benefits

- ✓ Zero water loss – no backwashing or flushing required
- ✓ Low maintenance
- ✓ Compact, versatile skid-mounted design – easy to position and install
- ✓ Durable stainless-steel construction – high resistance to corrosion
- ✓ Integrated magnets – enhanced removal of ferrous material
- ✓ Standard tun-dish integration – simplifies dosing

Key parameters

Max operating pressure	10 bar
Max operating temperature	90 °C
Filtration rating	≥ 1 micron

OPERATION

A sidestream flow of typically 5–10% of system flow is drawn by the on-board pump and passed through the filter, where particulates are removed. Depending on the required flow and desired filter life, a range of housing options are available. Filter element replacement depends on system fouling levels but is typically required on a monthly or quarterly basis.

Best suited for:

- ✓ Retrofits
- ✓ New installations
- ✓ Temporary installations for clean-up

Remarks

To ensure balance, the closed-loop pump should be adequately sized to accommodate the additional sidestream flow.

Applications

- ✓ High pressure hot water systems
- ✓ Thermal fluid systems
- ✓ Glycol and brine systems
- ✓ Heating and chilled water systems

HYDRASTREAM RANGE

Model	Max system volume (litres)	Flow rate (l/s)	Max flow rate (m ³ /h)	Pipe connection	Pipe connection outlet	Filter rate (micron)	Pump	TM65 Embodied Carbon Score CIBSE verified
Hydra050	34560	<0.4	1.44	½" BSP	½" BSP	>0.5	N/A	N/A
Hydra100	86400	<1	3.6	1" BSP	1" BSP	>0.5	N/A	186 kg CO ₂ e
Hydra200	302400	<3.5	12.6	2" BSP	2" BSP	>1	N/A	230 kg CO ₂ e
Hydra600	2592000	<30	108	6" PN10	6" PN10	>1	N/A	N/A

1" units utilise cartridge filtration, 2" units have a bag filter.

For higher pressure or temperature applications, speak to your representative. We can design and fabricate to project specific requirements.

SIDESTREAM INSTALLATION

- ✓ Dirt is heavier and tends to settle, so lower connections are typically more contaminated
- ✓ Taking off from the top of the pipe usually results in cleaner water
- ✓ Avoid take-off points inside bends or dead legs
- ✓ The return point should be at a similar pressure to the inlet connection
- ✓ Avoid connecting the filter across the main system pump, as this can disrupt system balance

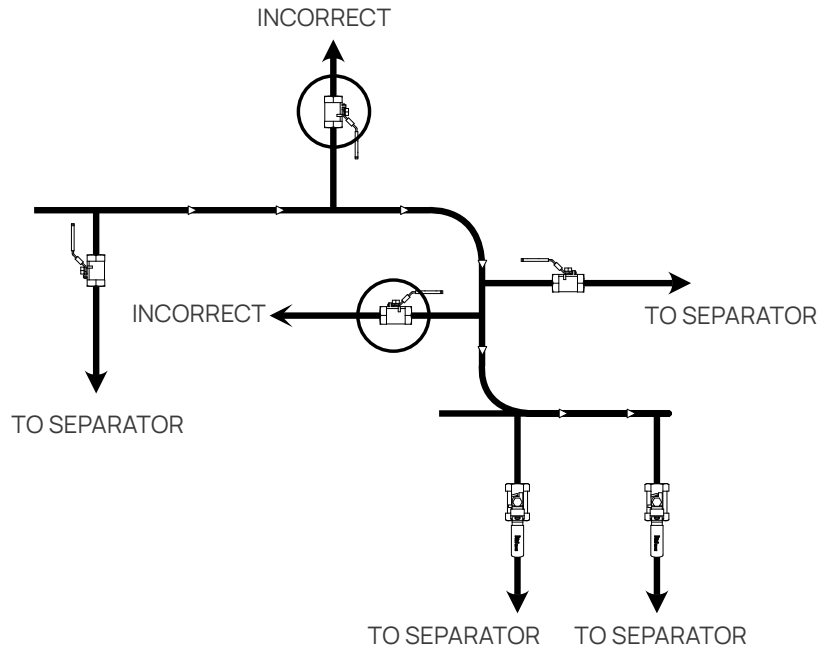

CONSULTANT SPECIFICATION EXAMPLE

The mechanical contractor shall supply and install a PED approved sidestream filtration system for the removal of particulates within heating and chilled water systems.

This design is based on the Hydrastream, utilising a bag filter, model reference HYDRA200 as manufactured by Fluid Dynamics (contact sales@evolvewater.co.uk).

On appointment, in order to confirm the most effective position in the closed circuit system for the sidestream filter, the mechanical contractor shall coordinate with the manufacturer, and take into account the water services design and local water quality.

The device shall generally be in accordance with the following parameters:

1. Connection type: 2" BSP
2. Outlet connection: 2" BSP
3. Design flow rate: 1 – 3.5 l/s
4. Pressure drop: 0.07 mbar

The sidestream filtration system shall consist of the following features:

1. WRAS approved components
2. Zero liquid discharge when utilising a bag filter on the cyclonic discharge
3. Permanent magnets for optimising ferric material removal
4. In-built tun-dish for dosing
5. Manufactured in a stainless steel housing with stainless steel fittings
6. Minimum warranty 2 years
7. BMS and bag full signal integrated into pump controls
8. 100% recyclable at end of effective life

It is preferred that the manufacturer is able to provide a mid-level LCA in line with the TM65 Embodied Carbon Calculation Methodology, in order to enable accurate environmental impact monitoring.

The device shall be installed in strict accordance with the manufacturer's literature.

The here above recommended specification clauses are intended to cover a wide range of installation applications. For a project specific specification, it is recommended to discuss with an Evolve Water representative.